

INSTRUCTIONS FOR INSTALLING A WATER FEEDER ASSEMBLY REPLACEMENT KIT OR A WATER FEEDER COVER ASSEMBLY REPLACEMENT KIT IN A NATIONAL VENDORS® , CROWN SEVENTY TWO® CDM-311 OR CDM-312 COLD DRINK MERCHANDISER, LSV-350 COLD DRINK UNIT, OR HCDM-360 HOT/COLD DRINK MERCHANDISER

CHECK THE PARTS RECEIVED IN THE KIT WITH THE PARTS LIST IN THESE INSTRUCTIONS. IF ANY PARTS ARE MISSING, CONTACT NATIONAL VENDORS' PARTS DEPARTMENT IMMEDIATELY.

These instructions cover the procedure for installing a Water Feeder Assembly or Water Feeder Cover Assembly Replacement kit in the Merchandisers mentioned above.

Read these instructions carefully and thoroughly before installing the kit. Retain these instructions for part number and installation information.

Water Feeder Assembly Replacement kit, part number 312-8172, contains the following parts:

Part Number	Description	Quantity
312-8149	Water Feeder Assembly	1
312-8170	Installation Instructions * * *	1

Water Feeder Cup Cover Assembly Replacement kit, part number 312-8171, contains the following parts:

Part Number	Description	Quantity
312-8158	Water Feeder Cup Cover Assembly	1
312-8170	Installation Instructions * * *	1

NOTE

- The Water Feeder Assembly included in the replacement kit is a direct replacement for CDM-311 and CDM-312 Merchandisers. For these Merchandisers, simply remove the defective Water Feeder Assembly and install the replacement. However, the Water Feeder Assembly must be adapted for use in either the LSV-350 Unit or the HCDM-360 Merchandiser. Section I covers adapting the Water Feeder Assembly for the LSV-350 Unit. Section II covers adapting the Water Feeder Assembly for the HCDM-360 Merchandiser.*
- The Water Feeder Cup Cover Assembly included in the replacement kit is a direct replacement for all merchandisers except the HCDM-360. Before installing the Water Feeder Cup Cover Assembly in the HCDM-360, the Float height MUST be adjusted as described in Section II, Step 2 of these instructions.*

TO INSTALL KITS

**SECTION I
PREPARING THE WATER FEEDER ASSEMBLY FOR
INSTALLATION IN A LSV-350 UNIT**

1. Remove the Feeder Cup Outlet Cap from the defective Water Feeder Assembly.
2. Remove the Water Feeder Cover Assembly from the replacement Water Feeder Assembly included in the kit, part number 312-8149.
3. Remove the Feeder Cup Insert from the shorter outlet on the bottom of the Feeder Cup. See Figure 1.
4. Fit the Feeder Cup Outlet Cap on the shorter outlet of the Feeder Cup as shown in Figure 1.

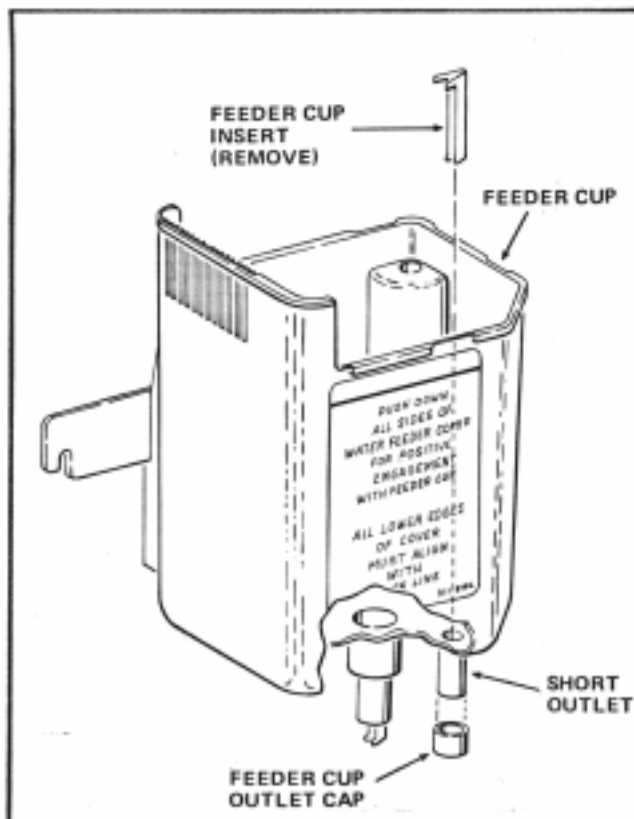

FIGURE 1

5. Install the Water Feeder Cover Assembly on the Feeder Cup, making sure that the Cover locks in place.
6. Install the replacement Water Feeder Assembly in the Unit.

SECTION II
PREPARING THE WATER FEEDER ASSEMBLY FOR
INSTALLATION IN AN HCDM-360 MERCHANDISER

1. Remove the Water Feeder Cover Assembly from the replacement Water Feeder Assembly included in the kit, part number 312-8149.
2. Adjust the Float height of the Water Feeder Cover Assembly as follows:
 - a. Remove the Lower Bushing and the Float from the Float Shaft of the Water Feeder Cover. See Figure 2.

NOTE

Before performing Step 2-b, make sure that the Float Shaft is screwed into the Switch Actuator as far as it will go and locked into place by the Nut w/lockwasher.

- b. Screw the Upper Bushing upward on the Float Shaft until the distance between the Upper Bushing and the flat portion of the Switch Actuator is $3/4"$ as shown in Figure 2.
 - c. Install the Float and Lower Bushing on the Float Shaft, screwing the Lower Bushing as far upward on the Shaft as it will go. See Figure 2.
3. Remove the Feeder Cup Insert from the longer Outlet on the bottom of the Feeder Cup. See Figure 3.
4. Measure $1/8"$ inch upward from the shoulder of the longer Outlet on the bottom of the Feeder Cup and mark the location. See Figure 3.
5. Using a hacksaw, cut off the bottom portion of the longer Outlet, cutting at the level marked in Step 4. See Figure 3.
6. Install the Water Feeder Cover Assembly on the Feeder Cup. Make sure that the Cover locks in place.
7. Install the replacement Water Feeder Assembly in the Merchandiser.

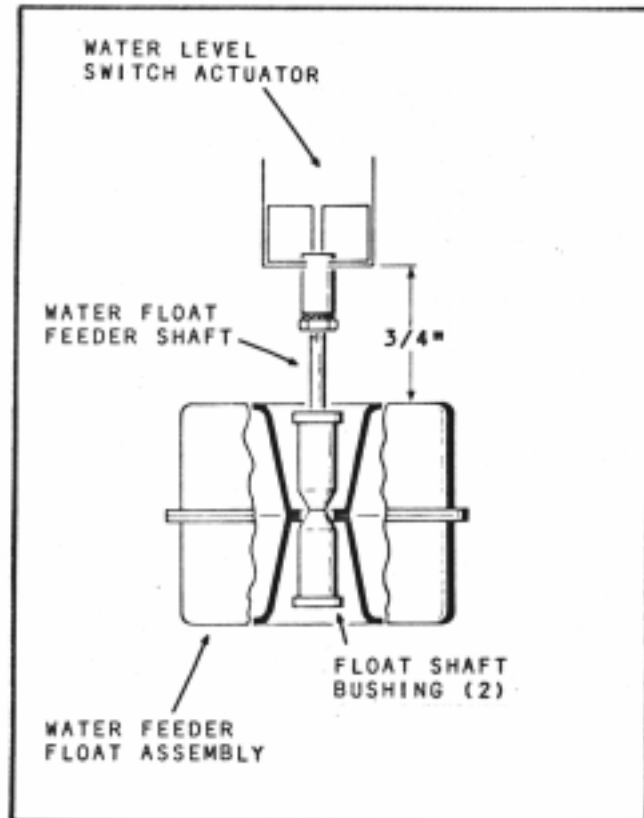

FIGURE 2

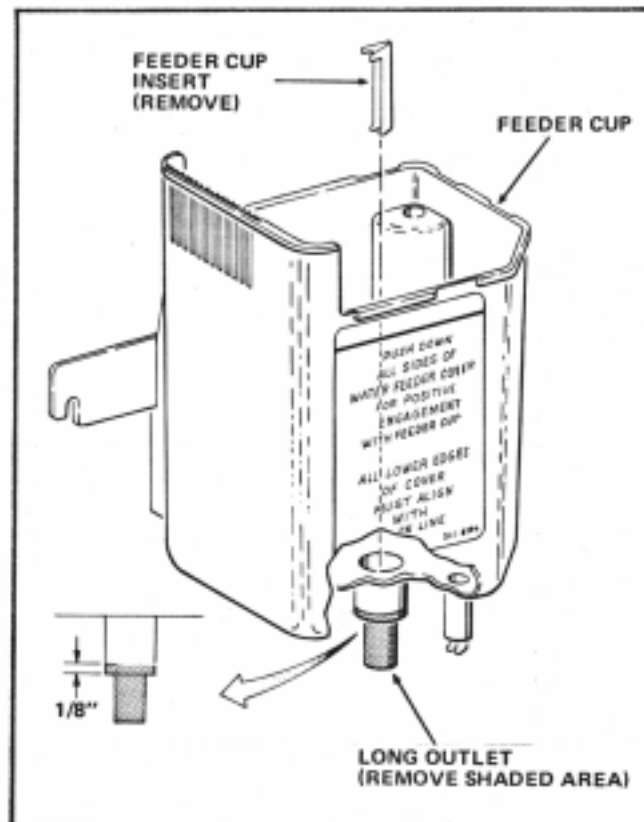

FIGURE 3